

# VS1001k - MPEG AUDIO CODEC

## Features

- MPEG audio layer 3 decoder (ISO11172-3)
- Supports MPEG 1 & 2, and 2.5 extensions, all their sample rates and bit rates, in mono and stereo
- Supports PCM input
- Supports VBR (variable bitrate)
- Can be used as a slave co-processor
- Operates with single clock 12..13 MHz or 24..26 MHz
- Extremely low-power operation
- On-chip high-quality stereo DAC with no phase error between channels
- Internal Op-Amp in BGA-49 and LQFP-48 packages
- Stereo earphone driver capable of driving a 30Ω load.
- Separate 2.5 .. 3.6V operating voltages for analog and digital
- 4 KiB On-chip RAM for user code
- Serial control and data interfaces
- New functions may be added with software

## Description

VS1001k is a single-chip solution for an MPEG layer 3 audio decoder. The chip contains a high-performance low-power DSP processor (VS\_DSP), working memory, 4 KiB program RAM and 0.5 KiB data RAM for user applications, serial control and input data interfaces, and a high-quality oversampling variable-sample-rate stereo DAC, followed by an earphone amplifier and a ground buffer.

VS1001k receives its input bitstream through a serial input bus, which it listens to as a system slave. The input stream is decoded and passed through a analog/digital hybrid volume control to an 18-bit oversampling multi-bit sigma-delta DAC. The decoding is controlled via a serial control bus. In addition to the basic decoding, it is possible to add application specific features, like DSP effects, to the user RAM memory.

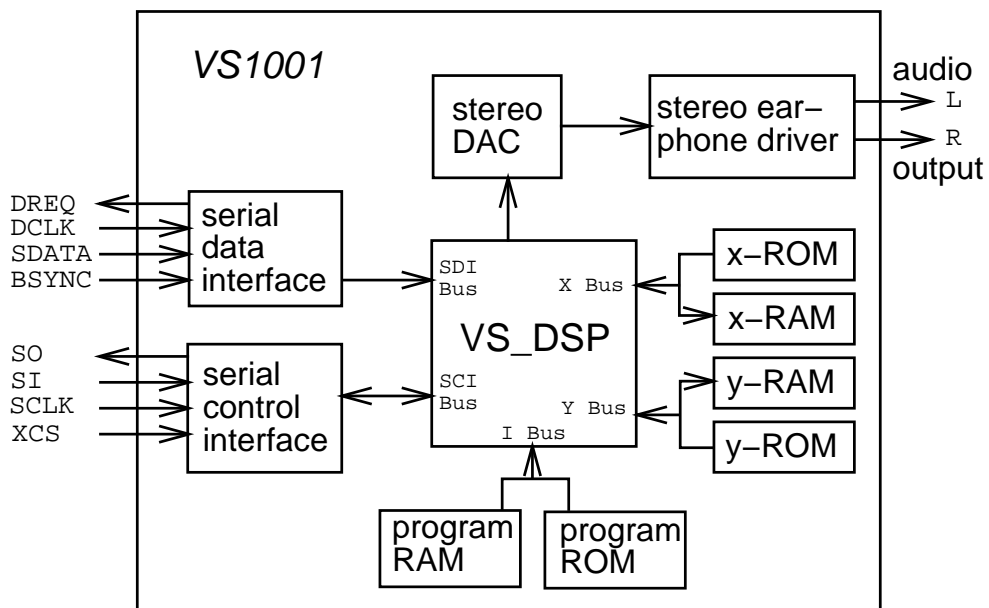
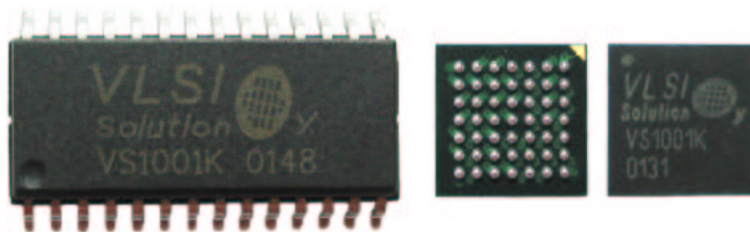

**Contents**

|   |           |
|---|-----------|
| <b>1 License</b>  | <b>7</b>  |
| <b>2 Characteristics &amp; Specifications</b>                   | <b>7</b>  |
| 2.1 Analog Characteristics . . . . .                            | 7         |
| 2.2 Power Consumption . . . . .                                 | 8         |
| 2.3 DAC Interpolation Filter Characteristics . . . . .          | 8         |
| 2.4 DAC Interpolation Filter Characteristics . . . . .          | 8         |
| 2.5 Absolute Maximum Ratings . . . . .                          | 8         |
| 2.6 Recommended Operating Conditions . . . . .                  | 9         |
| 2.7 Digital Characteristics . . . . .                           | 9         |
| 2.8 Switching Characteristics - Clocks . . . . .                | 10        |
| 2.9 Switching Characteristics - DREQ Signal . . . . .           | 10        |
| 2.10 Switching Characteristics - SPI Interface Output . . . . . | 10        |
| 2.11 Switching Characteristics - Boot Initialization . . . . .  | 10        |
| <b>3 Packages and Pin Descriptions</b>                          | <b>11</b> |
| 3.1 SOIC-28 . . . . .   | 11        |
| 3.2 BGA-49 . . . . .  | 12        |
| 3.3 LQFP-48 . . . . .   | 13        |
| <b>4 Connection Diagram, SOIC-28</b>                            | <b>14</b> |
| <b>5 Connection Diagram, BGA-49 and LQFP-48</b>                 | <b>15</b> |
| <b>6 SPI Buses</b>  | <b>16</b> |
| 6.1 General . . . . .   | 16        |

|          |  |           |
|----------|--|-----------|
| 6.2      | SPI Bus Pin Descriptions . . . . .                           | 16        |
| 6.3      | Serial Protocol for Serial Data Interface (SDI) . . . . .    | 16        |
| 6.4      | Serial Protocol for Serial Command Interface (SCI) . . . . . | 17        |
| 6.4.1    | General . . . . .  | 17        |
| 6.4.2    | SCI Read . . . . .   | 17        |
| 6.4.3    | SCI Write . . . . .  | 18        |
| 6.5      | SPI Timing Diagram . . . . .                                 | 19        |
| <b>7</b> | <b>Functional Description</b>                                | <b>20</b> |
| 7.1      | Main Features . . . . .                                      | 20        |
| 7.2      | Data Flow of VS1001k . . . . .                               | 20        |
| 7.3      | Serial Data Interface (SDI) . . . . .                        | 21        |
| 7.4      | Serial Control Interface (SCI) . . . . .                     | 21        |
| 7.5      | SCI Registers . . . . .                                      | 21        |
| 7.5.1    | MODE (RW) . . . . .  | 22        |
| 7.5.2    | STATUS (RW) . . . . .  | 24        |
| 7.5.3    | INT_FCNTLH (-) . . . . .                                     | 24        |
| 7.5.4    | CLOCKF (RW) . . . . .  | 24        |
| 7.5.5    | DECODE_TIME (R) . . . . .                                    | 24        |
| 7.5.6    | AUDATA (R) . . . . .   | 25        |
| 7.5.7    | WRAM (W) . . . . .   | 25        |
| 7.5.8    | WRAMADDR (W) . . . . .                                       | 25        |
| 7.5.9    | HDATA0 and HDATA1 (R) . . . . .                              | 26        |
| 7.5.10   | AIADDR (RW) . . . . .  | 27        |
| 7.5.11   | VOL (RW) . . . . .   | 27        |

|          |                                       |           |
|----------|---------------------------------------|-----------|
| 7.5.12   | RESERVED (RW) . . . . .               | 27        |
| 7.5.13   | AICTRL[x] (RW) . . . . .              | 27        |
| 7.6      | Stereo Audio DAC . . . . .            | 27        |
| <b>8</b> | <b>Operation</b>                      | <b>28</b> |
| 8.1      | Clocking . . . . .                    | 28        |
| 8.2      | Powerdown . . . . .                   | 28        |
| 8.3      | Hardware Reset . . . . .              | 28        |
| 8.4      | Software Reset . . . . .              | 28        |
| 8.5      | Play/Decode . . . . .                 | 29        |
| 8.6      | Sanity Checks . . . . .               | 29        |
| 8.7      | PCM Mode . . . . .                    | 29        |
| 8.8      | Testing . . . . .                     | 29        |
| 8.8.1    | Memory Test . . . . .                 | 30        |
| 8.8.2    | SCI Test . . . . .                    | 30        |
| 8.8.3    | Sine Test . . . . .                   | 31        |
| <b>9</b> | <b>Writing Software</b>               | <b>32</b> |
| 9.1      | When to Write Software . . . . .      | 32        |
| 9.2      | The Processor Core . . . . .          | 32        |
| 9.3      | User's Memory Map . . . . .           | 32        |
| 9.4      | Hardware Registers . . . . .          | 32        |
| 9.4.1    | SCI Registers, 0x4000 . . . . .       | 32        |
| 9.4.2    | Serial Registers, 0x4100 . . . . .    | 32        |
| 9.4.3    | DAC Registers, 0x4200 . . . . .       | 33        |
| 9.4.4    | Interrupt Registers, 0x4300 . . . . . | 33        |

|           |   |           |
|-----------|---|-----------|
| 9.5       | System Vector Tags . . . . .  | 34        |
| 9.5.1     | AudioInt, 0x4000..0x4001 . . . . .  | 34        |
| 9.5.2     | SpiInt, 0x4002..0x4003 . . . . .  | 34        |
| 9.5.3     | DataInt, 0x4004..0x4005 . . . . .   | 34        |
| 9.5.4     | UserCodec, 0x4008..0x4009 . . . . .                                       | 34        |
| 9.6       | System Vector Functions . . . . .   | 35        |
| 9.6.1     | WriteIRam(), 0x4010 . . . . .   | 35        |
| 9.6.2     | ReadIRam(), 0x4011 . . . . .  | 35        |
| 9.6.3     | DataWords(), 0x4012 . . . . .   | 36        |
| 9.6.4     | GetDataByte(), 0x4013 . . . . .   | 36        |
| 9.6.5     | GetDataWords(), 0x4014 . . . . .  | 36        |
| <b>10</b> | <b>VS1001 Version Changes</b>   | <b>37</b> |
| 10.1      | Changes Between VS1001h and Production Version VS1001k, 2001-08 . . . . . | 37        |
| 10.2      | Changes Between VS1001g and VS1001h, 2001-05 . . . . .                    | 37        |
| 10.3      | Changes Between VS1001d to VS1001g, 2001-03 . . . . .                     | 37        |
| <b>11</b> | <b>Document Version Changes</b>   | <b>38</b> |
| 11.1      | Changes Between Version 4.10 and 4.11 for VS1001k, 2003-09 . . . . .      | 38        |
| 11.2      | Changes Between Version 4.08 and 4.10 for VS1001k, 2003-07 . . . . .      | 38        |
| 11.3      | Changes Between Version 4.07 and 4.08 for VS1001k, 2003-03 . . . . .      | 38        |
| 11.4      | Changes Between Version 4.06 and 4.07 for VS1001k, 2003-03 . . . . .      | 38        |
| 11.5      | Changes Between Version 4.05 and 4.06 for VS1001k, 2002-09 . . . . .      | 38        |
| 11.6      | Changes Between Version 4.03 and 4.05 for VS1001k, 2002-08 . . . . .      | 38        |
| <b>12</b> | <b>Contact Information</b>  | <b>39</b> |

**List of Figures**

|    |   |    |
|----|---|----|
| 1  | Pin Configuration, SOIC-28. . . . .                                   | 11 |
| 2  | Pin Configuration, BGA-49. . . . .                                    | 12 |
| 3  | Pin Configuration, LQFP-48. . . . .                                   | 13 |
| 4  | Typical Connection Diagram Using SOIC-28. . . . .                     | 14 |
| 5  | Typical Connection Diagram Using BGA-49. . . . .                      | 15 |
| 6  | BSYNC Signal. . . . .   | 16 |
| 7  | SCI Word Read . . . . .   | 18 |
| 8  | SCI Word Write . . . . .  | 18 |
| 9  | SPI Timing Diagram. . . . .   | 19 |
| 10 | Data Flow of VS1001k. . . . .   | 20 |
| 11 | Built-In Bass/Treble Enhancer Frequency Response at 44.1 kHz. . . . . | 23 |
| 12 | User's Memory Map. . . . .  | 33 |

## 1 License

MPEG Layer-3 audio decoding technology licensed from Fraunhofer IIS and THOMSON multimedia.

Supply of this product only conveys a license for private, non-commercial use.

## 2 Characteristics & Specifications

Unless otherwise noted: AVDD=2.9..3.6V, DVDD=2.3..3.6V, TA=-30..+85°C, XTALI=24.576MHz, Full-Scale Output Sinewave at 1.526 kHz, measurement bandwidth 20..20000 Hz, analog output load 30Ω (no ground buffer) or 100Ω (with ground buffer), bitstream 128 kbits/s, local components as shown in Figures 4 and 5.

Note, that some analog values are in practice better than in these tables if chips are used within a limited temperature range and not too close to lower voltage limits.

### 2.1 Analog Characteristics

| Parameter                                       | Symbol | Min  | Typ              | Max  | Unit            |
|---|--------|------|------------------|------|-----------------|
| DAC Resolution                                  |        |      | 16               |      | bits            |
| Total Harmonic Distortion                       | THD    |      | 0.1              | 0.2  | %               |
| Dynamic Range (DAC unmuted, A-weighted)         | IDR    |      | 90               |      | dB              |
| S/N Ratio (full scale signal)                   | SNR    | 70   | 87               |      | dB              |
| Interchannel Isolation                          |        | 50   | 75               |      | dB              |
| Interchannel Gain Mismatch                      |        | -0.5 |                  | 0.5  | dB              |
| Frequency Response                              |        | -0.1 |                  | 0.1  | dB              |
| Frequency Response, AVDD = 2.8V                 |        | -0.3 |                  | 0.3  | dB              |
| Full Scale Output Voltage (Peak-to-peak)        |        | 1.4  | 1.8 <sup>1</sup> | 2.0  | V <sub>pp</sub> |
| Deviation from Linear Phase                     |        |      |                  | 5    | °               |
| Out of Band Energy                              |        |      | -60              |      | dB              |
| Out of Band Energy with Analog Filter           |        |      | -90              |      | dB              |
| Analog Output Load Resistance, no ground buffer | AOLR1  | 16   | 30 <sup>2</sup>  |      | Ω               |
| Analog Output Load Resistance, ground buffer    | AOLR2  | 16   | 100 <sup>2</sup> |      | Ω               |
| Analog Output Load Capacitance                  |        |      |                  | 1000 | pF              |

<sup>1</sup> 3.6 volts can be achieved with +-to-+ wiring for mono difference sound.

<sup>2</sup> AOLR1/2 may be much lower, but below *Typical* distortion performance may be compromised.

## 2.2 Power Consumption

| Parameter   | Symbol | Min | Typ  | Max   | Unit    |
|---|--------|-----|------|-------|---------|
| Power Supply Rejection                                      |        |     | 40   |       | dB      |
| Power Supply Consumption AVDD, Reset                        |        |     | 0.6  | 5.0   | $\mu$ A |
| Power Supply Consumption AVDD, no load                      |        | 3.0 | 4.5  | 6.0   | mA      |
| Power Supply Consumption AVDD, output loaded at 30 $\Omega$ |        | 4.0 | 5.5  | 40.0  | mA      |
| Power Supply Consumption AVDD, o. @ 30 $\Omega$ + GND-buf.  |        | 6.0 | 7.5  | 40.0  | mA      |
| Power Supply Consumption DVDD, Reset                        |        |     | 3.7  | 100.0 | $\mu$ A |
| Power Supply Consumption DVDD                               |        |     | 15.0 |       | mA      |

## 2.3 DAC Interpolation Filter Characteristics

| Parameter                 | Symbol | Min     | Typ   | Max         | Unit |
|---------------------------|--------|---------|-------|-------------|------|
| Passband (to -3dB corner) |        | 0       |       | 0.459Fs     | Hz   |
| Passband (Ripple Spec)    |        | 0       |       | 0.420Fs     | Hz   |
| Passband Ripple           |        |         |       | $\pm$ 0.056 | dB   |
| Transition Band           |        | 0.420Fs |       | 0.580Fs     | Hz   |
| Stop Band                 |        | 0.580Fs |       |             | Hz   |
| Stop Band Rejection       |        | 90      |       |             | dB   |
| Group Delay               |        |         | 15/Fs |             | s    |

Fs is conversion frequency

## 2.4 DAC Interpolation Filter Characteristics

| Parameter                   | Symbol | Min   | Typ | Max | Unit |
|-----------------------------|--------|-------|-----|-----|------|
| -3 dB bandwidth             |        | 300   |     |     | kHz  |
| Passband Response at 20 kHz |        | -0.05 |     |     | dB   |

## 2.5 Absolute Maximum Ratings

| Parameter                        | Symbol | Min      | Max      | Unit         |
|----------------------------------|--------|----------|----------|--------------|
| Analog Positive Supply           | AVDD   | -0.3     | 3.6      | V            |
| Digital Positive Supply          | DVDD   | -0.3     | 3.6      | V            |
| Current at Any Digital Output    |        |          | $\pm$ 50 | mA           |
| Voltage at Any Digital Input     |        | DGND-1.0 | DVDD+1.0 | V            |
| Operating Temperature            |        | -30      | +85      | $^{\circ}$ C |
| Functional Operating Temperature |        | -40      | +95      | $^{\circ}$ C |
| Storage Temperature              |        | -65      | +150     | $^{\circ}$ C |



## 2.6 Recommended Operating Conditions

| Parameter                     | Symbol    | Min              | Typ | Max | Unit |
|-------------------------------|-----------|------------------|-----|-----|------|
| Analog and Digital Ground     | AGND DGND |                  | 0.0 |     | V    |
| Positive Analog               | AVDD      | 2.5 <sup>1</sup> | 3.0 | 3.6 | V    |
| Ambient Operating Temperature |           | -30              |     | +85 | °C   |

<sup>1</sup> If AVDD is below 2.8 V, distortion performance may be compromised.

The following values are to be used when the clock doubler is active:

| Parameter                             | Symbol | Min | Typ    | Max | Unit |
|---------------------------------------|--------|-----|--------|-----|------|
| Positive Digital                      | DVDD   | 2.3 | 2.7    | 3.6 | V    |
| Input Clock Frequency                 | XTALI  |     | 12.288 | 13  | MHz  |
| Internal Clock Frequency <sup>1</sup> | CLKI   |     | 24.576 | 26  | MHz  |

<sup>1</sup> The maximum sample rate that may be decoded with correct speed is CLKI/512.

The following values are to be used when the clock doubler is inactive:

| Parameter                             | Symbol | Min | Typ    | Max | Unit |
|---------------------------------------|--------|-----|--------|-----|------|
| Positive Digital                      | DVDD   | 2.3 | 2.7    | 3.6 | V    |
| Input Clock Frequency                 | XTALI  |     | 24.576 | 26  | MHz  |
| Internal Clock Frequency <sup>1</sup> | CLKI   |     | 24.576 | 26  | MHz  |

<sup>1</sup> The maximum sample rate that may be decoded with correct speed is CLKI/512.

Note: With higher than typical voltages, VS1001k may operate with CLKI upto 30..32 MHz. However, the chips are not qualified for this kind of usage. If necessary, VLSI Solution Oy can qualify chips for higher clock rates for quantity orders.

## 2.7 Digital Characteristics

| Parameter                                    | Symbol | Min     | Typ | Max     | Unit |
|--|--------|---------|-----|---------|------|
| High-Level Input Voltage                     |        | 0.7DVDD |     |         | V    |
| Low-Level Input Voltage                      |        |         |     | 0.3DVDD | V    |
| High-Level Output Voltage at $I_O = -2.0$ mA |        | 0.7DVDD |     |         | V    |
| Low-Level Output Voltage at $I_O = 2.0$ mA   |        |         |     | 0.3DVDD | V    |
| Input Leakage Current                        |        |         |     | 1.0     | μA   |

## 2.8 Switching Characteristics - Clocks

| Parameter                           | Symbol | Min | Typ    | Max | Unit |
|-------------------------------------|--------|-----|--------|-----|------|
| Master Clock Frequency <sup>1</sup> | XTALI  |     | 12.288 |     | MHz  |
| Master Clock Frequency <sup>2</sup> | XTALI  |     | 24.576 |     | MHz  |
| Master Clock Duty Cycle             |        | 40  | 50     | 60  | %    |
| Clock Output                        | XTALO  |     | XTALI  |     | MHz  |

<sup>1</sup> Clock doubler active.

<sup>2</sup> Clock doubler inactive.

## 2.9 Switching Characteristics - DREQ Signal

| Parameter           | Symbol | Min | Typ | Max | Unit |
|---------------------|--------|-----|-----|-----|------|
| Data Request Signal | DREQ   |     |     | 200 | ns   |

## 2.10 Switching Characteristics - SPI Interface Output

| Parameter                 | Symbol | Min | Typ | Max       | Unit |
|---------------------------|--------|-----|-----|-----------|------|
| SPI Input Clock Frequency |        |     |     | 0.25×CLKI | MHz  |
| Rise time for SO          |        |     |     | 100       | ns   |

## 2.11 Switching Characteristics - Boot Initialization

| Parameter                         | Symbol | Min | Max   | Unit  |
|-----------------------------------|--------|-----|-------|-------|
| .RESET active time                |        | 2   |       | XTALI |
| .RESET inactive to software ready |        |     | 50000 | XTALI |

### 3 Packages and Pin Descriptions

#### 3.1 SOIC-28

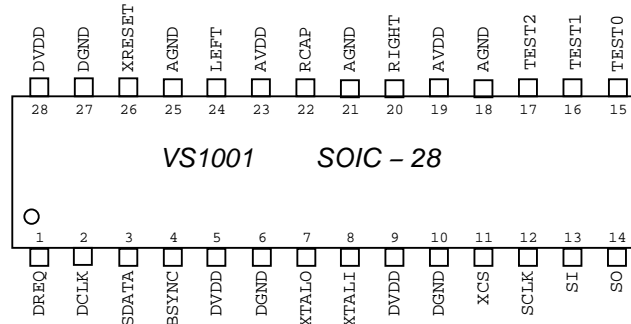

Figure 1: Pin Configuration, SOIC-28.

| Pin Name | Pin | Pin Type | Function                                  |
|----------|-----|----------|---|
| DREQ     | 1   | DO       | data request, input bus                   |
| DCLK     | 2   | DIO      | serial input data bus clock               |
| SDATA    | 3   | DI       | serial data input                         |
| BSYNC    | 4   | DI       | byte synchronization signal               |
| DVDD1    | 5   | PWR      | digital power supply                      |
| DGND1    | 6   | PWR      | digital ground                            |
| XTALO    | 7   | CLK      | crystal output                            |
| XTALI    | 8   | CLK      | crystal input                             |
| DVDD2    | 9   | PWR      | digital power supply                      |
| DGND2    | 10  | PWR      | digital ground                            |
| XCS      | 11  | DI       | chip select input (active low)            |
| SCLK     | 12  | DI       | clock for serial bus                      |
| SI       | 13  | DI       | serial input                              |
| SO       | 14  | DO3      | serial output                             |
| TEST0    | 15  | DI       | reserved for test, connect to DVDD        |
| TEST1    | 16  | DO       | reserved for test, <i>do not connect!</i> |
| TEST2    | 17  | DO       | reserved for test, <i>do not connect!</i> |
| AGND1    | 18  | PWR      | analog ground                             |
| AVDD1    | 19  | PWR      | analog power supply                       |
| RIGHT    | 20  | AO       | right channel output                      |
| AGND2    | 21  | PWR      | analog ground                             |
| RCAP     | 22  | AIO      | capacitance for reference                 |
| AVDD2    | 23  | PWR      | analog power supply                       |
| LEFT     | 24  | AO       | left channel output                       |
| AGND3    | 25  | PWR      | analog ground                             |
| XRESET   | 26  | DI       | active low asynchronous reset             |
| DGND3    | 27  | PWR      | digital ground                            |
| DVDD3    | 28  | PWR      | digital power supply                      |

Pin types:

| Type | Description                                | Type | Description         |
|------|--|------|---------------------|
| DI   | Digital input, CMOS Input Pad              | AI   | Analog input        |
| DO   | Digital output, CMOS Input Pad             | AO   | Analog output       |
| DIO  | Digital input/output                       | AIO  | Analog input/output |
| DO3  | Digital output, CMOS Tri-stated Output Pad | PWR  | Power supply pin    |

SOIC-28 package dimensions can be found at <http://www.vlsi.fi/vs1001/soic28.pdf>.

3.2 BGA-49

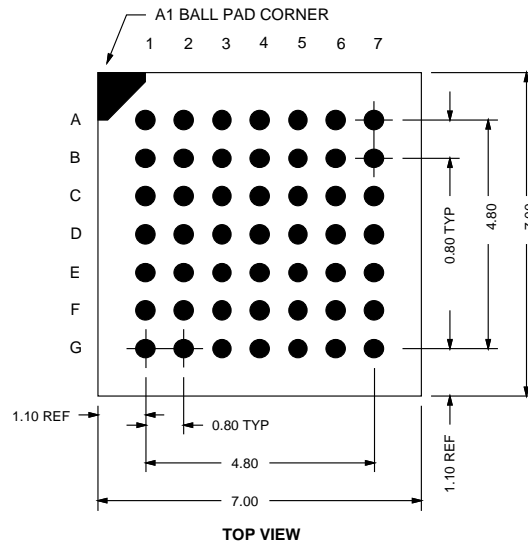

Figure 2: Pin Configuration, BGA-49.

| Pin Name | Ball | Pin Type | Function                                  |
|----------|------|----------|---|
| BSYNC    | E3   | DI       | byte synchronization signal               |
| DVDD1    | F3   | PWR      | digital power supply                      |
| DGND1    | F4   | PWR      | digital ground                            |
| XTAL0    | G3   | CLK      | crystal output                            |
| XTALI    | E4   | CLK      | crystal input                             |
| DVDD2    | F5   | PWR      | digital power supply                      |
| DGND2    | F6   | PWR      | digital ground                            |
| XCS      | G6   | DI       | chip select input (active low)            |
| SCLK     | D6   | DI       | clock for serial bus                      |
| SI       | E7   | DI       | serial input                              |
| SO       | D5   | DO3      | serial output                             |
| TEST0    | C6   | DI       | reserved for test, connect to DVDD        |
| TEST1    | C7   | DO       | reserved for test, <i>do not connect!</i> |
| TEST2    | B6   | DO       | reserved for test, <i>do not connect!</i> |
| AGND1    | C5   | PWR      | analog ground                             |
| AVDD1    | B5   | PWR      | analog power supply                       |
| RIGHT    | A6   | AO       | right channel output                      |
| AGND34   | B4   | PWR      | analog ground                             |
| GBGND    | A5   | PWR      | analog ground for ground buffer           |
| GBUF     | C4   | AO       | ground buffer                             |
| GBVDD    | A4   | PWR      | analog power supply for ground buffer     |
| RCAP     | B3   | AIO      | capacitance for reference                 |
| AVDD45   | A3   | PWR      | analog power supply                       |
| LEFT     | B2   | AO       | left channel output                       |
| AGND56   | A2   | PWR      | analog ground                             |
| XRESET   | B1   | DI       | active low asynchronous reset             |
| DGND3    | D2   | PWR      | digital ground                            |
| DVDD3    | D3   | PWR      | digital power supply                      |
| DREQ     | E2   | DO       | data request, input bus                   |
| DCLK     | E1   | DIO      | serial input data bus clock               |
| SDATA    | F2   | DI       | serial data input                         |

Not connected are: A1, A7, B7, C1, C2, C3, D1, D4, D7, E5, E6, F1, F7, G1, G2, G4, G5 and G7. For “Pin Types”, see Chapter 3.1. BGA-49 package dimensions are at <http://www.vlsi.fi/vs1001/bga49.pdf>.

### 3.3 LQFP-48

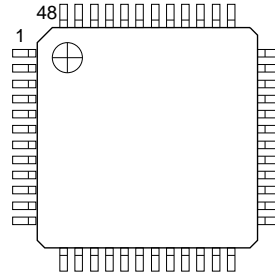

Figure 3: Pin Configuration, LQFP-48.

| Pin Name | Pin     | Pin Type | Function                                  |
|----------|---------|----------|---|
| nc       | 1,2     | -        |   |
| XRESET   | 3       | DI       | active low asynchronous reset             |
| DGND0    | 4       | PWR      | digital ground                            |
| nc       | 5       | -        |   |
| DVDD0    | 6       | PWR      | digital power supply                      |
| nc       | 7       | -        |   |
| DREQ     | 8       | DO       | data request, input bus                   |
| DCLK     | 9       | DI       | serial input data bus clock               |
| SDATA    | 10      | DI       | serial data input                         |
| nc       | 11,12   | -        |   |
| BSYNC    | 13      | DI       | byte synchronization signal               |
| DVDD1    | 14      | PWR      | digital power supply                      |
| nc       | 15      | -        |   |
| DGND1    | 16      | PWR      | digital ground                            |
| XTALO    | 17      | AO       | crystal output                            |
| XTALI    | 18      | AI       | crystal input                             |
| DVDD2    | 19      | PWR      | digital power supply                      |
| DGND2    | 20      | PWR      | digital ground                            |
| DGND3    | 21      | PWR      | digital ground                            |
| DGND4    | 22      | PWR      | digital ground                            |
| XCS      | 23      | DI       | chip select input (active low)            |
| nc       | 24...27 | -        |   |
| SCLK     | 28      | DI       | clock for serial bus                      |
| SI       | 29      | DI       | serial input                              |
| SO       | 30      | DO3      | serial output                             |
| nc       | 31      | -        |   |
| TEST0    | 32      | DI       | reserved for test, connect to DVDD        |
| TEST1    | 32      | DO       | reserved for test, <i>do not connect!</i> |
| TEST2    | 32      | DO       | reserved for test, <i>do not connect!</i> |
| nc       | 35,36   | -        |   |
| AGND0    | 37      | PWR      | analog ground, low-noise reference        |
| AVDD0    | 38      | PWR      | analog power supply                       |
| RIGHT    | 39      | AO       | right channel output                      |
| AGND1    | 40      | PWR      | analog ground                             |
| AGND2    | 41      | PWR      | analog ground                             |
| VCM      | 42      | AO       | feedback                                  |
| AVDD1    | 43      | PWR      | analog power supply                       |
| RCAP     | 44      | AIO      | capacitance for reference                 |
| AVDD2    | 45      | PWR      | analog power supply                       |
| LEFT     | 46      | AO       | left channel output                       |
| AGND3    | 47      | PWR      | analog ground                             |
| nc       | 48      | -        |   |

For “Pin Types”, see Chapter 3.1. LQFP-48 package dimensions are at <http://www.vlsi.fi/vs1001/lqfp48.pdf>.

### 4 Connection Diagram, SOIC-28

In this connection diagram, a SOIC-28 -packaged VS1001k is used.

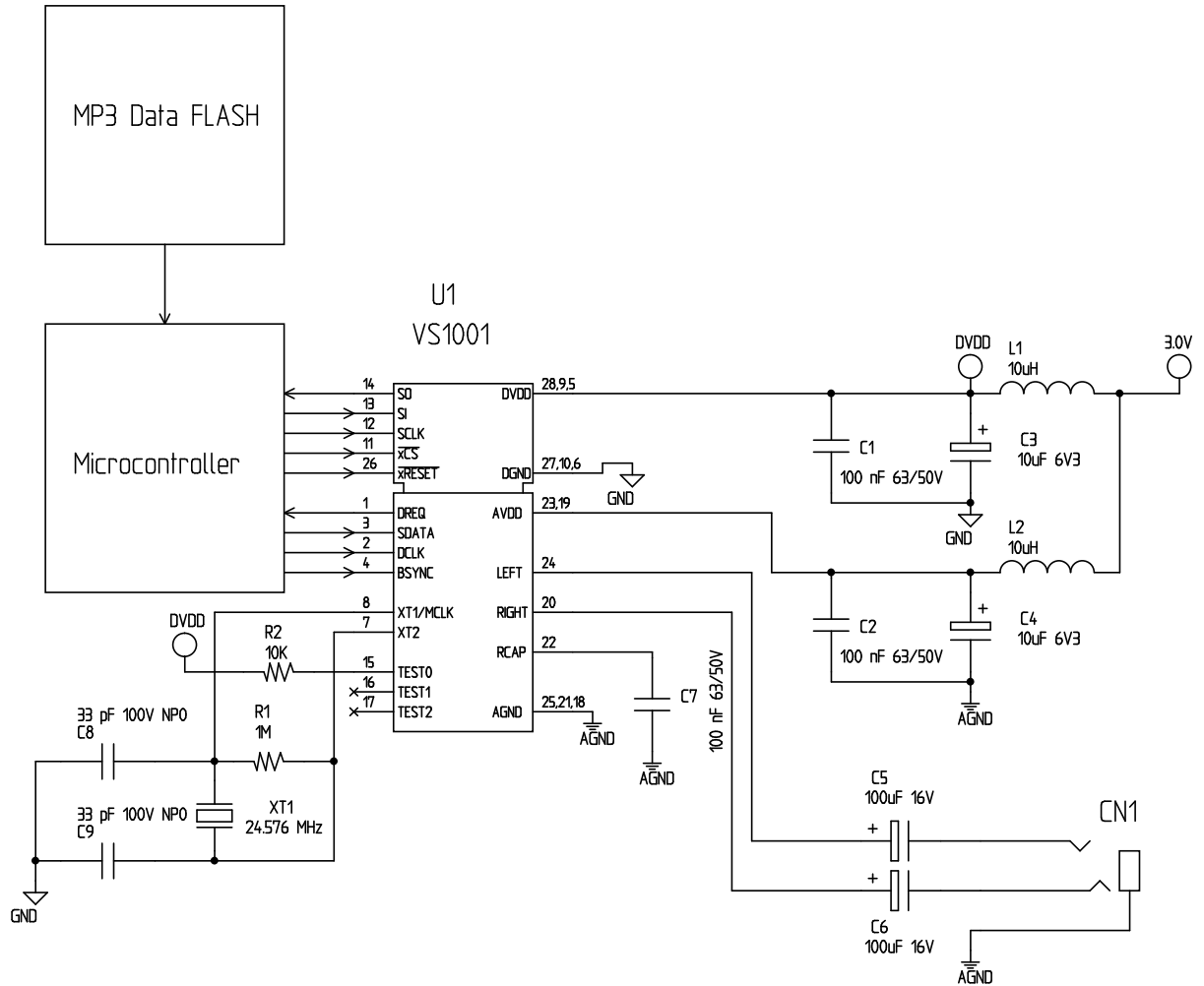

Figure 4: Typical Connection Diagram Using SOIC-28.

Ground buffer is not available for the SOIC-28 package; hence it is not used.

## 5 Connection Diagram, BGA-49 and LQFP-48

In this connection diagram, a BGA-49 or LQFP-48 packaged VS1001k is used. In this picture, ground buffer is active.

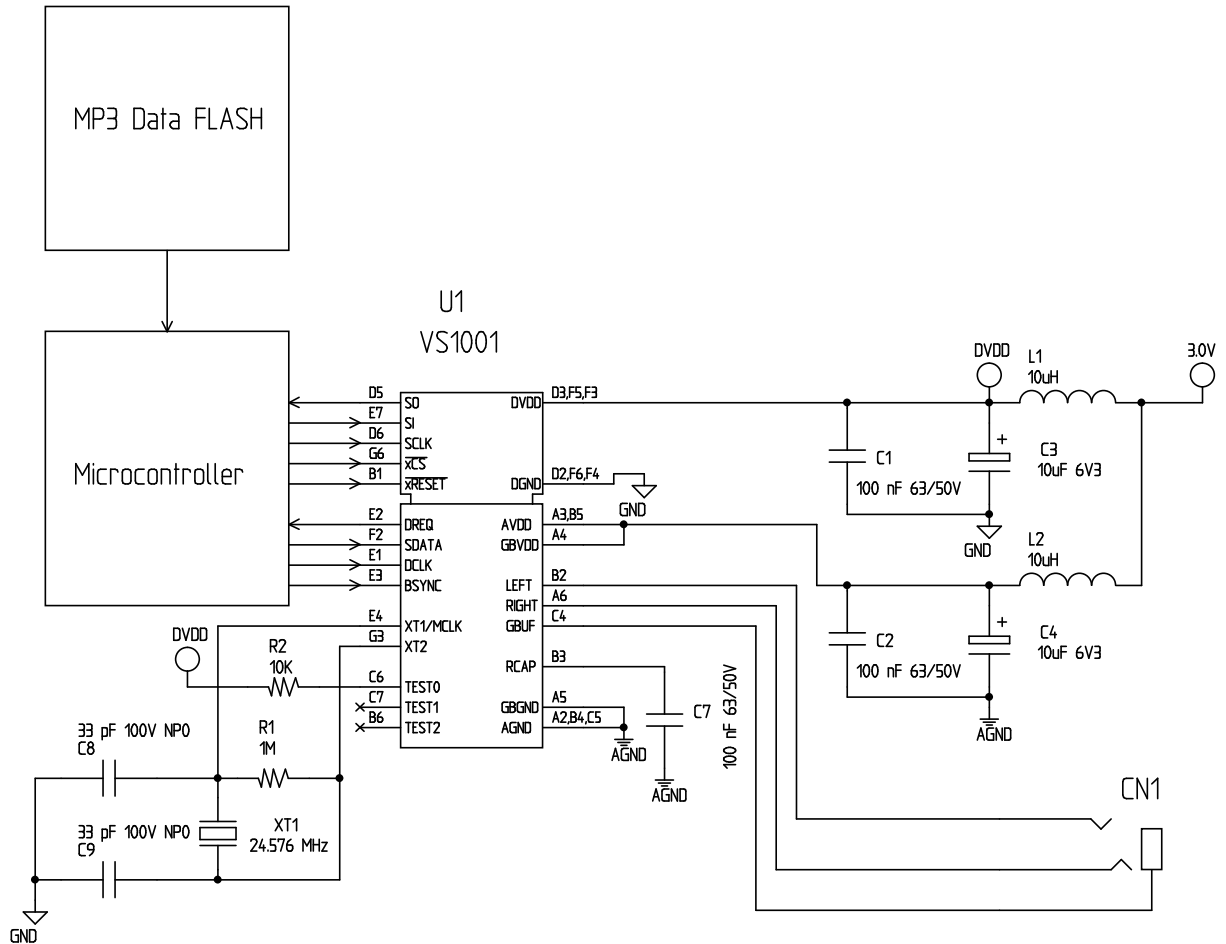

Figure 5: Typical Connection Diagram Using BGA-49.

Ground buffer GBUF can be used for common voltage (1.37 V) for earphones. This will eliminate the need for large isolation capacitors on line outputs, and thus the audio output pins from VS1001k may be connected directly to the earphone connector. If GBUF is not used, GBGND and GBVDD should not be connected.

## 6 SPI Buses

### 6.1 General

The SPI Bus - that was originally used in some Motorola devices - has been used for both VS1001k's Serial Data Interface SDI (Chapters 6.3 and 7.3) and Serial Control Interface SCI (Chapters 6.4 and 7.4).

### 6.2 SPI Bus Pin Descriptions

| SDI Pin | SCI Pin | Description  |
|---------|---------|--|
| -       | XCS     | Active low chip select input. A high level forces the serial interface into standby mode, ending the current operation. A high level also forces serial output (SO) to high impedance state. There is no chip select for SDI, which is always active.                                    |
| DCLK    | SCK     | Serial clock input. The serial clock is also used internally as the master clock for the register interface.<br>SCK can be gated or continuous. In either case, the first rising clock edge after XCS has gone low marks the first bit to be written (clock 0 in the following figures). |
| SDATA   | SI      | Serial input. SI is sampled on the rising SCK edge, if XCS is low.   |
| -       | SO      | Serial output. In reads, data is shifted out on the falling SCK edge. In writes SO is at a high impedance state.   |

### 6.3 Serial Protocol for Serial Data Interface (SDI)

The serial data interface can operate in either master or slave mode. In master mode, VS1001k generates the DCLK signal, which can be selected to be either 512 or 1024 kHz. In slave mode, the DCLK signal is generated by an external circuit.

The data (SDATA signal) can be clocked in at either the rising or falling edge of the DCLK. (Chapter 7.5).

The VS1001k chip assumes its input to be byte-synchronized. I.e. the internal operation of the decoder does not search for byte synchronization of the frames from the data stream, but instead assumes the data to be correctly byte-aligned. The bytes can be transmitted either MSB or LSB first, depending of contents of SCI register MODE (Chapter 7.5).

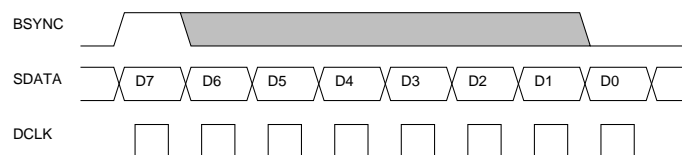

Figure 6: BSYNC Signal.

To ensure correct byte-alignment of the input bitstream, the serial data interface has a BSYNC signal.



The first DCLK sampling edge (rising or falling, depending on selected polarity), during which the BSYNC is high, marks the first bit of a byte (LSB, if LSB-first order is used, MSB, if MSB-first order is used). If BSYNC is not used, it must be tied to VCC externally and the master of the input serial interface must always sustain the correct byte-alignment. Using BSYNC is strongly recommended. For more details, look at the Application Notes for VS10XX.

The DREQ signal of the data interface is used in slave mode to signal if VS1001k's FIFO is capable of receiving more input data. If DREQ is high, VS1001k can take at least 32 bytes of data. When there is less than 32 bytes of free space, DREQ is turned low, and the sender should stop transferring new data. Because of the 32-byte safety area, the sender may send up to 32 bytes of data at a time without checking the status of DREQ, making controlling VS1001k easier for low-speed microcontrollers.

Note: DREQ may turn low or high at any time, even during a byte transmission. Thus, DREQ should only be used to decide whether to send more bytes. It should not abort a transmission that has already started.

## 6.4 Serial Protocol for Serial Command Interface (SCI)

### 6.4.1 General

The serial bus protocol for the Serial Command Interface SCI (Chapter 7.4) consists of an instruction byte, address byte and one 16-bit data word. Each read or write operation can read or write a single register. Data bits are read at the rising edge, so the user should not update data at the rising edge.

The operation is specified by an 8-bit instruction opcode. The supported instructions are read and write. See table below.

| Instruction |           |            |
|-------------|-----------|------------|
| Name        | Opcode    | Operation  |
| READ        | 0000 0011 | Read data  |
| WRITE       | 0000 0010 | Write data |

Note: After using the Serial Command Interface, it is not allowed to send SCI or SDI data for 5 microseconds.

### 6.4.2 SCI Read

VS1001k registers are read by the following sequence. First, XCS line is pulled low to select the device. Then the READ opcode (0x3) is transmitted via the SI line followed by an 8-bit word address. After the address has been read in, any further data on SI is ignored. The 16-bit data corresponding to the received address will be shifted out onto the SO line.

XCS should be driven high after the data has been shifted out. In that case, the word address will be incremented and data corresponding to the next address will be shifted out. After the last word has been shifted out, XCS should be driven high to end the READ sequence.

Word read is shown in Figure 7.

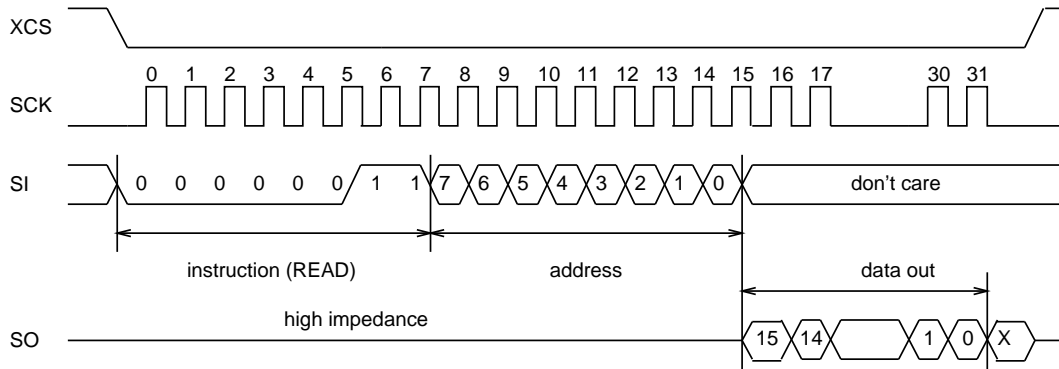

Figure 7: SCI Word Read

### 6.4.3 SCI Write

VS1001k registers are written by the following sequence. First, XCS line is pulled low to select the device. Then the WRITE opcode (0x2) is transmitted via the SI line followed by an 8-bit word address.

After the word has been shifted in, XCS should be pulled high to end the WRITE sequence. XCS low to high transition must occur after SCLK high to low transition corresponding to LSB of the last word.

Single word write is shown in Figure 8.

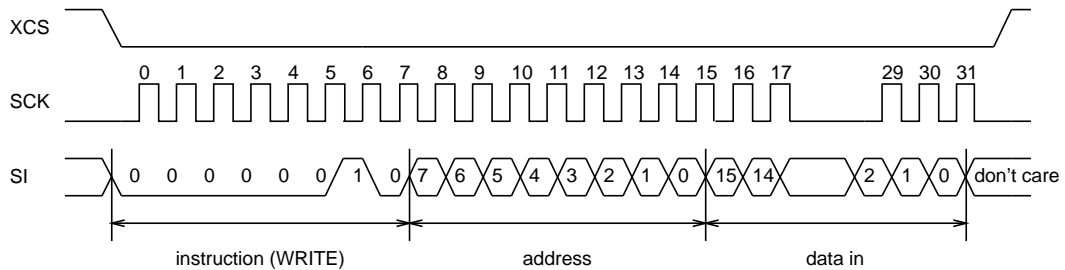

Figure 8: SCI Word Write

### 6.5 SPI Timing Diagram

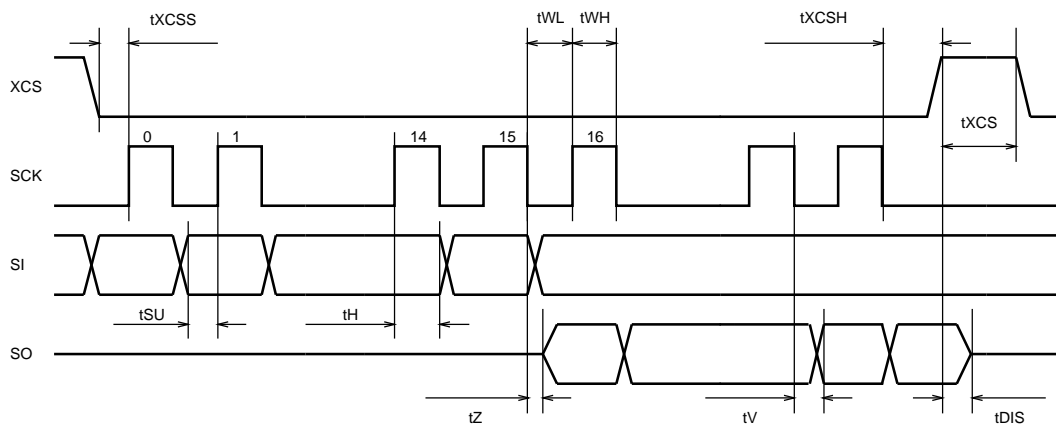

Figure 9: SPI Timing Diagram.

| Symbol     | Min | Max | Unit         |
|------------|-----|-----|--------------|
| $t_{XCSS}$ | 5   |     | ns           |
| $t_{SU}$   | 10  |     | ns           |
| $t_H$      | 42  |     | ns           |
| $t_Z$      |     | 42  | ns           |
| $t_{WL}$   | 100 |     | ns           |
| $t_{WH}$   | 100 |     | ns           |
| $t_V$      |     | 42  | ns           |
| $t_{XCSH}$ | 10  |     | ns           |
| $t_{XCS}$  | 2   |     | XTALI cycles |
| $t_{DIS}$  |     | 1   | XTALI cycles |

Note: As  $t_{XCS}$  must be at least 2 clock cycles, the maximum speed for the SPI bus is 1/4 of VS1001k's internal clock speed. For details, see Application Notes for VS10XX.

## 7 Functional Description

### 7.1 Main Features

VS1001k is based on a proprietary digital signal processor, VS\_DSP. It contains all the code and data memory needed for MPEG audio decoding, together with serial interfaces, a multirate stereo audio DAC and analog output amplifiers and filters.

VS1001k can play all MPEG 1 and 2 layer 3 files, as well as so-called MPEG 2.5 layer 3 extension files with all sample rates and bitrates. In addition, variable bitrate (VBR) is also supported. With VBR, and depending on the song, near-cd quality can be achieved with approximately 100 kbits/s for stereo music sampled at 44100 Hz, whereas old encoders required 128 kbits/s for the same task. As both commercial and free (<http://www.mp3dev.org/>) high-quality VBR encoders are nowadays widely available, MP3 format is getting better as it is maturing.

### 7.2 Data Flow of VS1001k

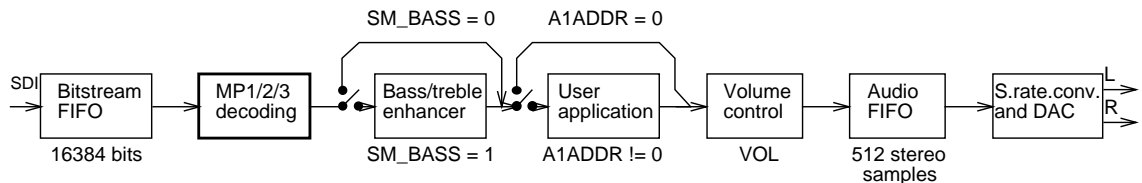

Figure 10: Data Flow of VS1001k.

First, MP3 data is input through the SDI bus.

After decoding, data may be sent to the Bass/treble enhancer depending on SCI register MODE's bit SM.BASS.

Then, if SCI register AIADDR is non-zero, application code is executed from the address pointed to by AIADDR. For more details, see Chapters 7.5.10 and Application Notes for VS10XX.

After the optional user application, the signal is fed to the volume control unit, which also copies the data to the Audio FIFO.

The Audio FIFO holds the data that is read by the Audio interrupt (Chapter 9.5.1) and fed to the sample rate converter and DACs. The size of the audio FIFO is 512 stereo (2×16-bit) samples

The sample rate converter converts all different sample rates to CLKI/512 and feeds the data to the DAC, which in order makes a stereo in-phase signal. This signal is then forwarded to the earphone amplifier.

### 7.3 Serial Data Interface (SDI)

The serial data interface is meant for transferring compressed MPEG audio data.

Also several different tests may be activated through SDI as described in Chapter 8.

### 7.4 Serial Control Interface (SCI)

The serial control interface is compatible with the SPI bus specification. Data transfers are always 16-bits. The VS1001k is controlled by writing and reading the registers of the interface.

The main controls of the control interface are:

- control of the operation mode
- uploading user programs
- access to header data
- status information
- access to decoded digital data
- feeding input data

### 7.5 SCI Registers

| Name        | Type | addr | Function                             |
|-------------|------|------|--------------------------------------|
| MODE        | RW   | 0    | mode control                         |
| STATUS      | RW   | 1    | status of VS1001k                    |
| INT_FCTLH   | -    | 2    | internal register, never use         |
| CLOCKF      | RW   | 3    | clock freq + doubler                 |
| DECODE_TIME | R    | 4    | decode time in seconds               |
| AUDATA      | R    | 5    | misc. audio data                     |
| WRAM        | W    | 6    | RAM write program                    |
| WRAMADDR    | W    | 7    | base address for RAM write           |
| HDATA0      | R    | 8    | read header data                     |
| HDATA1      | R    | 9    | read header data                     |
| AIADDR      | RW   | 10   | start address of application         |
| VOL         | RW   | 11   | volume control                       |
| RESERVED    | -    | 12   | reserved for VS1002 use, don't touch |
| AICTRL[x]   | RW   | 13+x | 2 application control registers      |

x = [0 .. 1]

All registers are filled with zeros at hardware reset.

### 7.5.1 MODE (RW)

MODE is used to control the operation of VS1001k.

| Bit | Name       | Function                             | Value | Description           |
|-----|------------|--------------------------------------|-------|-----------------------|
| 0   | SM_DIFF    | differential                         | 0     | normal in-phase audio |
|     |            |                                      | 1     | left channel inverted |
| 1   | SM_FFWD    | fast forward                         | 0     | normal playback       |
|     |            |                                      | 1     | fast forward on       |
| 2   | SM_RESET   | soft reset                           | 0     | no reset              |
|     |            |                                      | 1     | reset                 |
| 3   | SM_UNUSED1 | set to 0                             | 0     | Set to 0              |
| 4   | SM_PDOWN   | powerdown                            | 0     | power on              |
|     |            |                                      | 1     | powerdown             |
| 5   | SM_UNUSED2 | set to 0                             | 0     | Set to 0              |
| 6   | SM_UNUSED3 | set to 0                             | 0     | Set to 0              |
| 7   | SM_BASS    | bass/treble enhancer                 | 0     | off                   |
|     |            |                                      | 1     | on                    |
| 8   | SM_DACT    | DCLK active edge                     | 0     | rising                |
|     |            |                                      | 1     | falling               |
| 9   | SM_BYTEORD | Byte order on serial input bus       | 0     | MSB first             |
|     |            |                                      | 1     | MSB last              |
| 10  | SM_IBMODE  | input bus mode                       | 0     | slave                 |
|     |            |                                      | 1     | master                |
| 11  | SM_IBCLK   | input bus clk when VS1001k is master | 0     | 512 kHz               |
|     |            |                                      | 1     | 1024 kHz              |

When SM\_DIFF is set, the player inverts the left output. For a stereo input, this creates a virtual surround, and for a mono input this effectively creates a differential left/right signal.

By setting SM\_FFWD the player starts to accept SCI data at a high speed, and just decodes the audio headers silently without playing any data. This can be used to fast-forward data with safe landing. Register DECODE\_TIME is updated during a fast-forward just as normal.

By setting SM\_RESET to 1, the player is reset.

SM\_UNUSED1 should always be set to 0.

Bit SM\_PDOWN overrides any other: it turns VS1001k into powerdown mode, where the only operational part is the control bus.

SM\_UNUSED2 and SM\_UNUSED3 should always be set to 0.

Bit SM\_BASS turns on the built-in Bass and Treble enhancer. The frequency response of the enhancer when the sample rate is 44.1 kHz is shown in Figure 11. For other sample frequencies the response frequency axis must be adjusted accordingly. Example: If the sample rate is 48 kHz, the 1 kHz frequency in the figure is actually  $1 \text{ kHz} \times 48 \text{ kHz} / 44.1 \text{ kHz} = 1.09 \text{ kHz}$ . For details of how much extra processing

power is needed when activating this feature, see Application Notes for VS10XX.

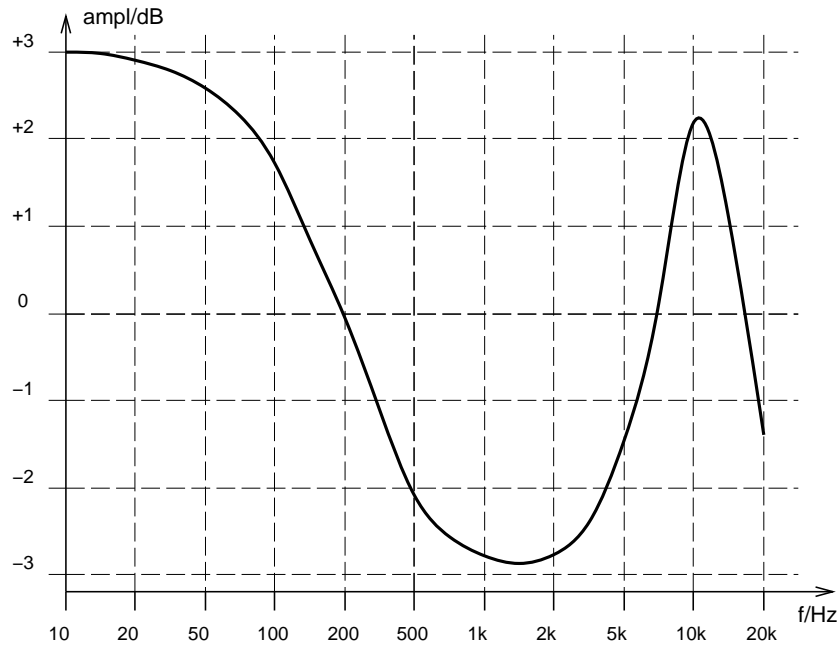

Figure 11: Built-In Bass/Treble Enhancer Frequency Response at 44.1 kHz.

SM.DACT defines the active edge of data clock for SDI.

SM.BYTEORD defines the data order inside a byte for SDI. Bytes are, however, still sent in the default order.

SM.IBMODE sets input bus to master mode. Master mode has not been tested, and its use is not recommended.

SM.IBCLK sets the bus clock speed when VS1001k is the master.

### 7.5.2 STATUS (RW)

STATUS contains information on the current status of the VS1001k. Bits 1 and 0 are used to control analog output volume: 0 = -0 dB, 1 = -6 dB, 3 = -12 dB. Bit 2 is analog powerdown bit. When set to 1, analog is put to powerdown.

Note: writing to register VOL will automatically set the analog output volume, and muting if necessary. Thus, the user needn't worry about this register.

### 7.5.3 INT\_FCNTLH (-)

INT\_FCTLH is not a user-accessible register.

### 7.5.4 CLOCKF (RW)

CLOCKF is used to tell if the input clock XTALI is running at something else than 24.576 MHz. XTALI is set in 2 kHz steps. Thus, the formula for calculating the correct value for this register is  $XTALI/2000$  (XTALI is in Hz). Values may be between 0..32767, although hardware limits the highest allowed speed. Also, with lower-than 24.576 MHz speeds all sample rates and bit-stream widths are no longer available.

Setting the MSB of CLOCKF to 1 activates internal clock-doubling. A clock of upto 15 MHz may be doubled depending on the voltage provided to the chip.

Note: CLOCKF must be set before beginning decoding MP3 data; otherwise the sample rate will not be set correctly.

Example 1: For a 26 MHz clock the value would be  $26000000/2000 = 13000$ .

Example 2: For a 13 MHz external clock and using internal clock-doubling for a 26 MHz internal frequency, the value would be  $0x8000 + (13000000/2000) = 39268$ .

Example 3: For a 24.576 MHz clock the value would be either  $24576000/2000 = 12288$ , or just the default value 0. For this clock frequency, CLOCKF doesn't need to be set at all.

### 7.5.5 DECODE\_TIME (R)

When decoding correct data, current decoded time is shown in this register in full seconds.



### 7.5.6 AUDATA (R)

When decoding correct data, the current bitrate in kbits/s can be found in bits 8..0 of AUDATA. For a variable bitrate bitstream, the current bitstream width is displayed. Bits 12..9 contains an index to the sample rate. The indices are shown in the table below. Bits 14..13 are not in use and always set to 0. Bit 15 is 0 for mono data and 1 for stereo.

| Bits 12..9 | Sample Rate/Hz |
|------------|----------------|
| 0b0000     | Unknown        |
| 0b0001     | 44100          |
| 0b0010     | 48000          |
| 0b0011     | 32000          |
| 0b0100     | 22050          |
| 0b0101     | 24000          |
| 0b0110     | 16000          |
| 0b0111     | 11025          |
| 0b1000     | 12000          |
| 0b1001     | 8000           |

### 7.5.7 WRAM (W)

WRAM is used to upload application programs to program RAM. The start address must be initialized by writing to the WRAMADDR register prior to the first call of WRAM. value will be used. As 16 bits of data can be transferred with one WRAM write, and the program word is 32 bits, two consecutive writes are needed for each program word. The byte order is big-endian (i.e. MSBs first). After each full-word write, the internal pointer is autoincremented.

### 7.5.8 WRAMADDR (W)

WRAMADDR is used to set the program address for following WRAM writes. User program space is between addresses 0x4000 .. 0x43ff (with addresses 0x4000 .. 0x401f being reserved by the system), but for writes through the WRAM mechanism, they are visible at addresses 0x4000 higher. Thus, if the programmer wish to write his application to address 0x4167, he should write  $0x4167 + 0x4000 = 0x8167$  to WRAMADDR.

7.5.9 HDAT0 and HDAT1 (R)

| Bit          | Function    | Value | Explanation        |
|--------------|-------------|-------|--------------------|
| HDAT1[15:5]  | syncword    | 2047  | stream valid       |
| HDAT1[4:3]   | ID          | 3     | ISO 11172-3 1.0    |
|              |             | 2     | MPG 2.0 (1/2-rate) |
|              |             | 1     | MPG 2.5 (1/4-rate) |
|              |             | 0     | MPG 2.5 (1/4-rate) |
| HDAT1[2:1]   | layer       | 3     | I                  |
|              |             | 2     | II                 |
|              |             | 1     | III                |
|              |             | 0     | reserved           |
| HDAT1[0]     | protect bit | 1     | No CRC             |
|              |             | 0     | CRC protected      |
| HDAT0[15:12] | bitrate     |       | ISO 11172-3        |
| HDAT0[11:10] | sample rate | 3     | reserved           |
|              |             | 2     | 32/16/8 kHz        |
|              |             | 1     | 48/24/12 kHz       |
|              |             | 0     | 44/22/11 kHz       |
| HDAT0[9]     | pad bit     | 1     | additional slot    |
|              |             | 0     | normal frame       |
| HDAT0[8]     | private bit |       | not defined        |
| HDAT0[7:6]   | mode        | 3     | mono               |
|              |             | 2     | dual channel       |
|              |             | 1     | joint stereo       |
|              |             | 0     | stereo             |
| HDAT0[5:4]   | extension   |       | ISO 11172-3        |
| HDAT0[3]     | copyright   | 1     | copyrighted        |
|              |             | 0     | free               |
| HDAT0[2]     | original    | 1     | original           |
|              |             | 0     | copy               |
| HDAT0[1:0]   | emphasis    | 3     | CCITT J.17         |
|              |             | 2     | reserved           |
|              |             | 1     | 50/15 microsec     |
|              |             | 0     | none               |

When read, HDAT0 and HDAT1 contain header information that is extracted from MPEG stream being currently being decoded. Right after resetting VS1001k, 0 is automatically written to both registers, indicating no data has been found yet.

The “sample rate” field in HDAT0 is interpreted as follows: if the “ID” field in HDAT1 is '1', the highest sample rate is used. If “ID” is '0', half sample rate is used. For '2' and '3', the lowest sample rate is used.

Note: The sample rate, stereo/mono and bitrate information can more easily be read from register AU-DATA.

### 7.5.10 AIADDR (RW)

AIADDR indicates the start address of the application code written earlier through WRAMADDR and WRAM registers. If no application code is used, this register should not be initialized, or it should be initialized to zero. For more details, see Application Notes for VS10XX.

### 7.5.11 VOL (RW)

VOL is a volume control for the player hardware. For each channel, a value in the range of 0 .. 255 may be defined to set its attenuation from the maximum volume level (in 0.5 dB steps). The left channel value is then multiplied by 256 and the values are added. Thus, maximum volume is 0 and total silence is 65535. Example: for a volume of -2.0 dB for the left channel and -3.5 dB for the right channel:  $(4 \times 256) + 7 = 1031$ . Note, that at startup volume is set to full volume. Resetting the software does not reset the volume setting.

Note: Setting the volume to total silence (255 for both left and right channels), will turn analog power off. This will save power, but also cause a slight snap in the earphones. If you want to turn the volume off but don't want this snap, turn the volume only to 254 for both channels (0xFEFE).

### 7.5.12 RESERVED (RW)

This register has been reserved for future use.

### 7.5.13 AICTRL[x] (RW)

AICTRL[x] -registers (  $x=[0 .. 1]$  ) can be used to access the user's application program.

## 7.6 Stereo Audio DAC

The decoded digital data is transformed into analog format by an 18-bit oversampling multi-bit sigma-delta DA-converter. The oversampled output is low-pass filtered by an on-chip analog filter. The output rate of the DA-converter is always 1/4 of the clock rate, or 128 times the highest usable sample rate. For instance for a 24.576 MHz clock, the DA-converter operates at 128x48 kHz, which is 6.144 MHz. If the input sample rate is other than 48 kHz, it is internally converted to 48 kHz by the DAC. This removes the need for complex PLL-based clocking schemes and still allows the use of several sample rates with one fixed master clock frequency.

The outputs can be separately muted by the user. If the output of the decoder is invalid or input data is not received fast enough, analog outputs are automatically muted. The analog outputs have buffers that are capable of driving 30Ω loads with a maximum of 50nF capacitance.

## 8 Operation

### 8.1 Clocking

The VS1001k chip operates typically on a single 24.576 MHz fundamental frequency master clock. This clock can be generated by external circuitry (connected to pin XTALI) or by the internal clock crystal interface (pins XTALI and XTALO). This clock is sufficient to support a high quality audio output for almost all the standard sample rates and bit-rates (see Application Notes for VS10XX).

Note: Oscillators above 24.576 MHz are usually so-called 3<sup>rd</sup> harmonic clocks, which have a fundamental frequency of 1/3 of the nominal clock frequency. With such an oscillator, VS1001 would be running at the base frequency, if working at all. Thus, for instance, if you run VS1001 with a 32 MHz 3<sup>rd</sup> harmonic clock, you usually end up running the chip at  $32 \text{ MHz} / 3 = 10.67 \text{ MHz}$ .

### 8.2 Powerdown

In powerdown mode the chip only monitors the control bus. The analog output drivers are turned off and the processor remains in hold-state.

### 8.3 Hardware Reset

When the XRESET -signal is driven low, VS1001k is reset and all the control registers and internal states are set to the initial values. XRESET-signal is asynchronous to any external clock. The reset mode doubles as a full-powerdown mode, where both digital and analog parts of VS1001k are in minimum power consumption stage, and where clocks are stopped. Also XTALO and XTALI are grounded.

After a hardware reset (or at power-up), set the basic software registers such as VOL for volume (and CLOCKF if the input clock is anything else than 24.576 MHz) before starting decoding.

### 8.4 Software Reset

Between any two MP3 files, the decoder software has to be reset. This is done by activating bit 2 in SCI's MODE register (Chapter 7.5.1). Then wait for at least 2  $\mu\text{s}$ , then look at DREQ. DREQ will stay down for at least 6000 clock cycles, which means an approximate 250  $\mu\text{s}$  delay if VS1001k is run at 24.576 MHz. When DREQ goes up, write at least one zero to SDI. After this, you may continue playback as usual.

If you want to make sure VS1001k doesn't cut the ending of low-bitrate data streams, it is recommended to feed 2048 zeros to the SDI bus before activating the reset bit (DREQ must be respected just as with normal SDI data). This will make sure all frames have been decoded before resetting the chip.

## 8.5 Play/Decode

This is the normal operation mode of VS1001k. The SDI data is decoded. Decoded samples are converted to analog domain by the internal DAC. If there are errors in the decoding process, the error flags of SCI's HDAT0 and HDAT1 are set accordingly. In case there are serious errors in the input data, decoding is still continued, but the analog outputs are muted.

When there is no valid input for decoding, VS1001k goes into idle mode (lower power consumption than during decoding) and actively monitors the serial data input for valid data. The data input does not need to be clocked (DCLK) when no data is sent.

The software needs to be reset between MPEG audio stream files. See for the Chapter "Testing" to see how it is done.

## 8.6 Sanity Checks

Although VS1001k checks extensively for bad MP3 streams, it may happen that it encounters a bitstream that makes the firmware's recovery code fail. This may particularly happen during fast forward and fast backwards operations, where the data where the microcontroller lands the MP3 decoder may not be a valid header.

The microcontroller should keep a look at the data speeds VS1001k requires. If data input either stops completely (DREQ always inactive) for a whole second, or if VS1001k requires more than 60 KiB data in any single second, it is the responsibility of the microcontroller to either reset the software. If that doesn't help, a hardware reset should be issued.

## 8.7 PCM Mode

VS1001k can be used as a Digital-to-Analog converter (DAC) by feeding PCM data. A convenient way to use VS1001k as a DAC is to load *SDI PCM Extension for VS1001k* software from VLSI Solution's home page at <http://www.vlsi.fi/vs1001/software/>.

The SDI PCM Extension makes it possible for the user to use SDI to feed 8-bit or 16-bit PCM samples in mono or stereo at any sample rate up to 48 kHz (with nominal 24.576 MHz operating frequency).

## 8.8 Testing

There are several test modes in VS1001k, which allow the user to perform memory tests, SCI bus tests, and several different sine wave tests ranging from 250 Hz to 1500 Hz.

All tests are started in a similar way: VS1001 is hardware reset, and then a test command is sent to the SDI bus. Each test is started by sending a 4-byte special command sequence, followed by 4 zeros. The sequences are described below.

### 8.8.1 Memory Test

Memory test mode is initialized with the 8-byte sequence 0x4D 0xEA 0x6D 0x54 0 0 0 0. After this command (and its required 4 zeros), wait for 500000 clock cycles. The result can be read from the SCI register HDAT0, and 'one' bits are interpreted as follows:

| Bit(s) | Meaning                     |
|--------|-----------------------------|
| 0      | Good X ROM                  |
| 1      | Good Y ROM (high)           |
| 2      | Good Y ROM (low)            |
| 3      | Good Y RAM                  |
| 4      | Good X RAM                  |
| 5      | Good Instruction RAM (high) |
| 6      | Good Instruction RAM (low)  |
| 7      | Unused                      |

All tests are non-destructive and interrupts are disabled during testing. Thus, no user software or data is harmed by the tests.

Instruction ROM cannot be tested with software.

### 8.8.2 SCI Test

Sci test is initialized with the 8-byte sequence 0x53 0x70 0xEE  $n$  0 0 0 0, where  $n - 48$  is the register number to test. The content of the given register is read and copied to HDAT0. If the register to be tested is HDAT0, the result is copied to HDAT1.

Example: if  $n$  is 48, contents of SCI register 0 (MODE) is copied to HDAT0.

### 8.8.3 Sine Test

Sine test is initialized with the 8-byte sequence: 0x53 0xEF 0x6E  $n$  0 0 0 0, where  $n$  (48..119) defines the sine test to use. If we define  $FsIdx = (n - 48) \bmod 9$  and  $FSin = (n - 48) / 9$ , the following tables may be used:

| FsIdx | Fs       | FSin | Length of Sin  |
|-------|----------|------|----------------|
| 0     | 44100 Hz | 0    | 32.000 samples |
| 1     | 48000 Hz | 1    | 16.000 samples |
| 2     | 32000 Hz | 2    | 10.667 samples |
| 3     | 22050 Hz | 3    | 8.000 samples  |
| 4     | 24000 Hz | 4    | 6.400 samples  |
| 5     | 16000 Hz | 5    | 5.333 samples  |
| 6     | 11025 Hz | 6    | 4.571 samples  |
| 7     | 12000 Hz | 7    | 4.000 samples  |
| 8     | 8000 Hz  |      |                |

Example: Sine test is called with a test value of 62.  $62 - 48 = 14$ ,  $FsIdx = 5$  and  $FSin = 1$ . From the tables we get the sample rate 16000 Hz, and the sine wave length, which is 16 samples. Thus, we'll get a 1 kHz voice.

To exit the sine test, send the sequence 0x45 0x78 0x69 0x74 0 0 0 0.

Note: The sine test signals go through the digital volume control, so it is possible to test channels separately.

## **9 Writing Software**

### **9.1 When to Write Software**

User software is required when a user wishes to add some own functionality like DSP effects or tone controls to VS1001k. Some tone controls are available from VLSI Solution, but if a user wishes to go further than that or use VS1001k in some unexpected way, this is how to do it.

However, most of the users of VS1001k don't need to worry about writing their own code, or this chapter.

### **9.2 The Processor Core**

VS\_DSP is a 16/32-bit DSP processor core that can very well also be used as an all-purpose processor. The VLSI Solution's free VSKIT Software Package contains all the tools and documentation needed to write, simulate and debug Assembly Language or Extended ANSI C programs for the VS\_DSP processor core.

The VSKIT Software Package is available on request from VLSI Solution.

### **9.3 User's Memory Map**

User's Memory Map is shown in Figure 12.

### **9.4 Hardware Registers**

All hardware registers are located in X memory.

#### **9.4.1 SCI Registers, 0x4000**

All SCI registers described in Chapter 7.5 can be found here between 0x4000..0x40FF.

#### **9.4.2 Serial Registers, 0x4100**

SER\_DATA (0x4100) contains the last data value read from the data bus. The LSB of SER\_DREQ (0x4101) defines the status of the DREQ signal.



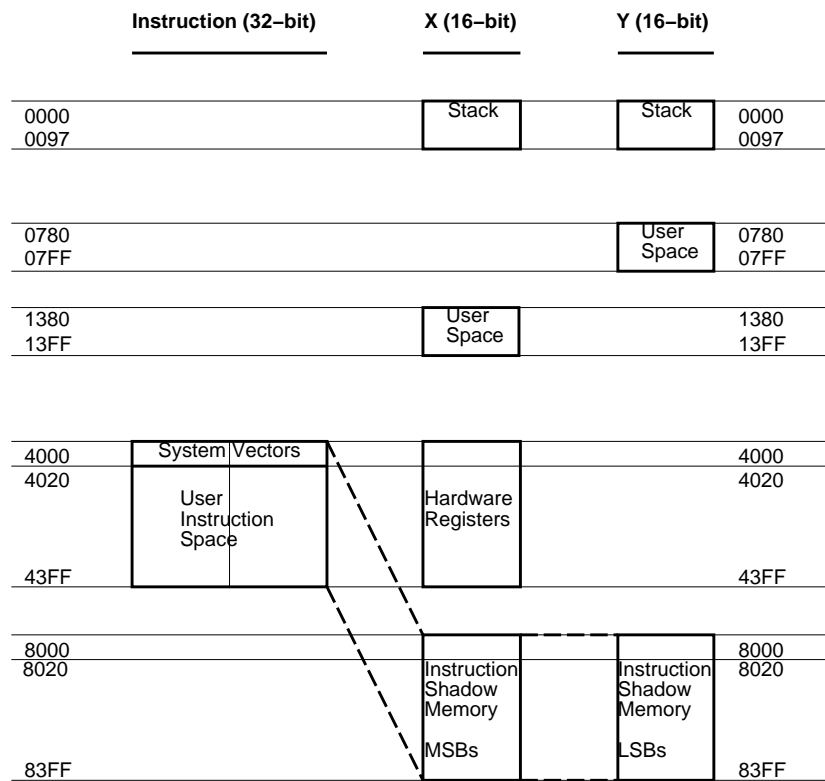

Figure 12: User's Memory Map.

### 9.4.3 DAC Registers, 0x4200

DAC data should be written at each audio interrupt to DAC\_LEFT (0x4200) and DAC\_RIGHT (0x4201) as signed values. INT\_FCTLL (0x4202) is not a user-serviceable register.

### 9.4.4 Interrupt Registers, 0x4300

INT\_ENABLE (0x4300) controls the interrupts. Bit 0 switches the DAC interrupt on (1) and off (0), bit 1 controls the SCI interrupt, and bit 2 controls the DATA interrupt. It may take upto 6 clock cycles before changing this register has any effect.

By writing any value to INT\_GLOB\_DIS (0x4301) adds one to the interrupt counter and effectively disables all interrupts. It may take upto 6 clock cycles before writing this register has any effect.

Writing any value to INT\_GLOB\_ENA (0x4302) subtracts one from the interrupt counter. If the interrupt counter becomes zero, interrupts selected with INT\_ENABLE are restored. An interrupt routine should always write to this register as the last thing it does, because interrupts automatically add one to the interrupt counter, but subtracting it back to its initial value is on the responsibility of the user. It may take upto 6 clock cycles before writing this register has any effect.

By reading INT\_COUNTER (0x4303) the user may check if the interrupt counter is correct or not. If the register is not 0, interrupts are disabled. This register may not be written to.

## 9.5 System Vector Tags

The System Vector Tags are tags that may be replaced by the user to take control over several decoder functions.

### 9.5.1 AudioInt, 0x4000..0x4001

Normally contains the following VS\_DSP assembly code:

```
j dac_int
stx mr1,(i6)+1 ; sty i7,(i6)
```

The user may, at will, replace the first instruction with either a *j* or *jmp* command to gain control over the audio interrupt. It is not recommended to change the instruction at 0x4001.

### 9.5.2 SpiInt, 0x4002..0x4003

Normally contains the following VS\_DSP assembly code:

```
j spi_int
stx mr1,(i6)+1 ; sty i7,(i6)
```

The user may, at will, replace the first address with either a *j* or *jmp* command to gain control over the SCI interrupt. It is not recommended to change the instruction at 0x4003.

### 9.5.3 DataInt, 0x4004..0x4005

Normally contains the following VS\_DSP assembly code:

```
j data_int
stx mr1,(i6)+1 ; sty i7,(i6)
```

The user may, at will, replace the first address with either a *j* or *jmp* command to gain control over the MP3 data interrupt. It is not recommended to change the instruction at 0x4005.

### 9.5.4 UserCodec, 0x4008..0x4009

Normally contains the following VS\_DSP assembly code:

```
jr
nop
```

If the user wants to take control away from the standard decoder, the first instruction should be replaced with an appropriate jump command to user's own code.

Unless the user is feeding MP3 data at the same time, the system activates the user program in less than 1 ms. After this, the user should steal interrupt vectors from the system, and then insert user programs.

## 9.6 System Vector Functions

The System Vector Functions are pointers to some functions that the user may call to help implementing his own applications.

### 9.6.1 WriteIRam(), 0x4010

VS\_DSP C prototype:

```
void WriteIRam(register __i0 u_int16 *addr, register __a1 u_int16 msW, register __a0 u_int16 lsW);
```

This is the only supported way to write to the User Instruction RAM. This is because Instruction RAM cannot be written when program control is in RAM. Thus, the actual implementation of this function is in ROM, and here is simply a tag to that routine.

Note: Instruction RAM is shadowed 0x4000 addresses higher in the X and Y RAMs. Thus, if you want to write to instruction address 0x4020, *addr* must be  $0x4020 + 0x4000 = 0x8020$ .

### 9.6.2 ReadIRam(), 0x4011

VS\_DSP C prototype:

```
u_int32 ReadIRam(register __i0 u_int16 *addr);
```

This is the only supported way to read from the User Instruction RAM. This is because Instruction RAM cannot be read when program control is in RAM. Thus, the actual implementation of this function is in ROM, and here is simply a tag to that routine.

A1 contains the MSBs and a0 the LSBs of the result.

Note: Instruction RAM is shadowed 0x4000 addresses higher in the X and Y RAMs. Thus, if you want to read from instruction address 0x4020, *addr* must be  $0x4020 + 0x4000 = 0x8020$ .

### 9.6.3 DataWords(), 0x4012

VS\_DSP C prototype:

```
u_int16 DataWords(void);
```

If the user has taken over the normal operation of the system by switching the pointer in UserCodec to point to his own code, he may read data from the Data Interface through this and the following two functions. This function returns the number of data words (each containing two bytes of data) that can be read. If there is not enough data available, data acquisition functions GetDataByte() and GetDataWords() may NOT be called!

### 9.6.4 GetDataByte(), 0x4013

VS\_DSP C prototype:

```
u_int16 GetDataByte(void);
```

Reads and returns one data byte from the Data Interface.

Before calling this function, always check first that there are at least 1 word waiting with function DataWords().

### 9.6.5 GetDataWords(), 0x4014

VS\_DSP C prototype:

```
void GetDataWords(register __i0 __y u_int16 *d, register __a0 u_int16 n);
```

Read  $n$  data byte pairs and copy them in big-endian format (first byte to MSBs) to  $d$ .

Before calling this function, always check first that there are at least  $1+n$  words waiting with function DataWords().

## 10 VS1001 Version Changes

This chapter describes changes between different generations of VS1001.

Note: VS1001k is the final, production version of VS1001.

### 10.1 Changes Between VS1001h and Production Version VS1001k, 2001-08

- When the chip is reset with pin XRESET, XTALO and XTALI are driven to ground.
- Running with normal clock earlier required slightly different clock generation than for clock-doubled (see Chapters 4 and 5). This is no longer the case.
- Lots of new SCI register MODE bits: SM\_DIFF, SM\_FFWD, SM\_BASS. For details, see Chapter 7.5.1.
- Default is now to only decode MP3.
- 20..60 mV DAC offset corrected.
- A firmware bug made it impossible to decode 320 kbits/s MP3 data. This has been corrected.
- A hardware bug made it practically impossible to load code to RAM. This has been corrected.

### 10.2 Changes Between VS1001g and VS1001h, 2001-05

- Analog voltage requirements have been lowered. Now full gain can be achieved with a 2.7 V analog input voltage, whereas 3.4 V was needed before.

### 10.3 Changes Between VS1001d to VS1001g, 2001-03

- Clock is now adjustable, in VS1001d only 24.576 MHz could be used.
- Clock doubler added.
- VS1001d played 48 kHz instead of 12 or 24 kHz, this is corrected.

## 11 Document Version Changes

This chapter describes the most important changes to this document.

### 11.1 Changes Between Version 4.10 and 4.11 for VS1001k, 2003-09

- Minor modifications to front page.
- Moved all Application Notes to a separate document, VS10XX Application Notes.

### 11.2 Changes Between Version 4.08 and 4.10 for VS1001k, 2003-07

- Added LQFP-48 packaging, Chapter 3.3.
- Removed package figure for BGA-49 and provided an URL instead.

### 11.3 Changes Between Version 4.07 and 4.08 for VS1001k, 2003-03

- Removed MP1 and MP2 functionality due to firmware problems.
- Removed Chapter Errata.

### 11.4 Changes Between Version 4.06 and 4.07 for VS1001k, 2003-03

- Removed DAC mode. A more efficient and convenient way for PCM playback files is presented in Chapter 8.7.

### 11.5 Changes Between Version 4.05 and 4.06 for VS1001k, 2002-09

- Added discussions of fundamental frequency and 3<sup>rd</sup> harmonic clocks to Chapter 8.1.

### 11.6 Changes Between Version 4.03 and 4.05 for VS1001k, 2002-08

- Clarified Chapter 8.8, Testing.
- Added Application Note: Quick Startup / Seeing If Analog Works.
- Added comments on how DREQ works with DAC mode to Chapter DAC Mode.
- Replaced A1CTRL with AICTRL and A1ADDR with AIADDR throughout the datasheet.
- Added list of not connected pins, and replaced incorrect “Pin Type” description for GBUF from PWR to AO in Chapter 3.2, Packages and Pin Descriptions / BGA-49.
- HDAT1[0] polarity was wrong in Chapter 7.5.9, corrected.

## 12 Contact Information

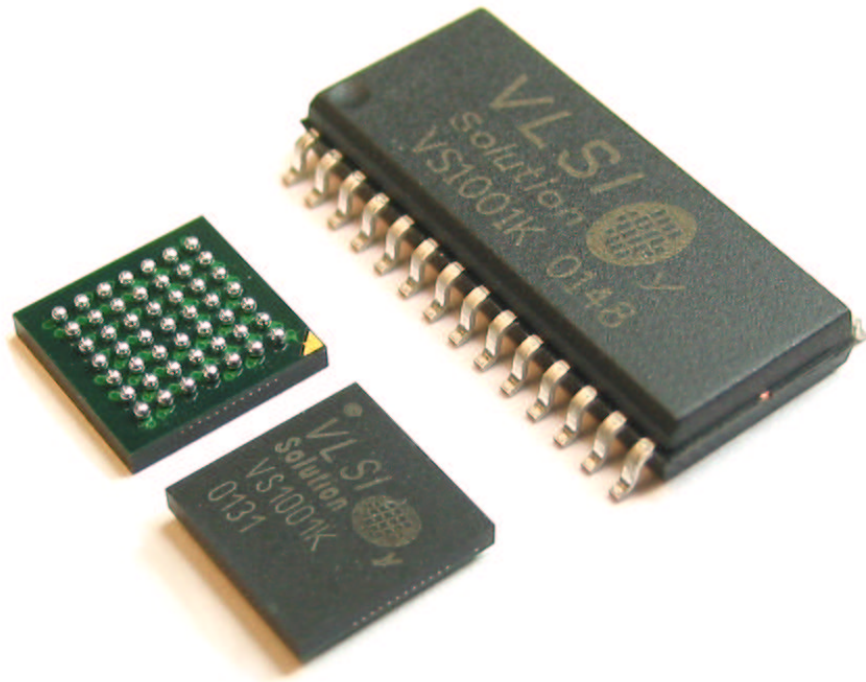

VLSI Solution Oy  
Hermiankatu 6-8 C  
FIN-33720 Tampere  
FINLAND

Fax: +358-3-316 5220  
Phone: +358-3-316 5230  
Email: sales@vlsi.fi  
URL: <http://www.vlsi.fi/>

Note: If you have questions, first see <http://www.vlsi.fi/vs1001/faq/>.